

DIY Parquet Nightstand

Addicted2DIY.com

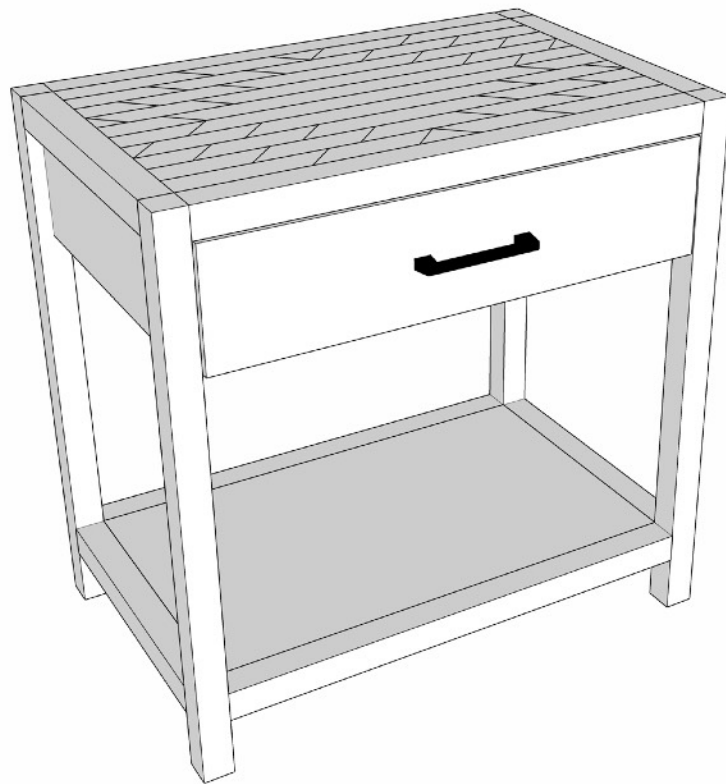
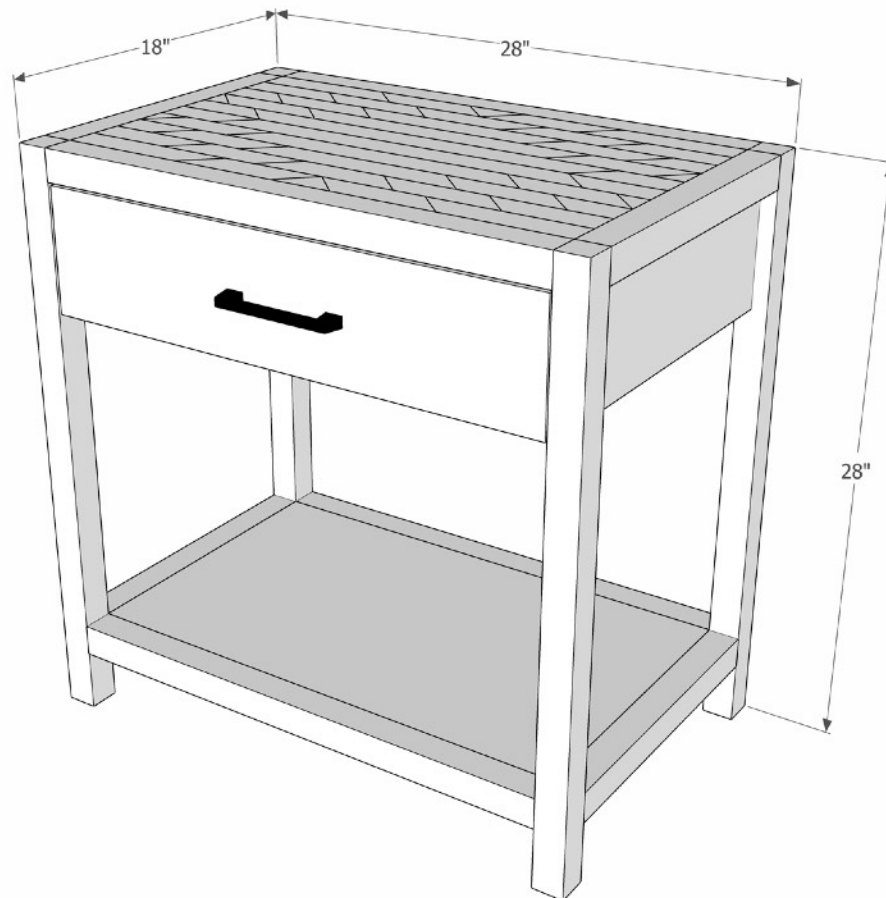

Before beginning this project...

please read through all of the plans as well as the video tutorial associated with this project . Always use safety precautions whenever using power tools and follow the manufacturer's suggested guidelines. Make sure to wear proper safety protection (eye protection, hearing protection, etc.) before beginning any project. Cut all pieces per the measurements in the plans, unless noted otherwise.



Materials and Cut List:

Materials Needed (for one night stand):

3 - 2x2 pine @ 8' long
1 - 1x6 @ 8' long
1 - 2' x 4' sheet 1/2" veneer plywood (or baltic birch)
1 - 2' x 4' sheet 3/4" veneer plywood
3 - 1x2 pine @ 8' long
1 1/2" pocket screws
1 1/4" pocket screws
1" pocket screws (not pan head)
1 1/4" wood screws
1" wood screws
Wood glue
220 grit sandpaper
1" brad nails
1 1/4" pin nails (or just glue the pieces down)
14" drawer slides (bottom or side mount)
Cabinet pull

Cut List:

4 - 2x2 @ 28" long
4 - 2x2 @ 25" long
4 - 2x2 @ 15" long
2 - 1x6 @ 15" long
1 - 1x6 @ 25" long
1 - 1x6 ripped down to 5 3/8" at 24 3/4" long (drawer front)
2 - 3/4" plywood @ 25" x 15"
2 - 1/2" plywood @ 24" x 4"
2 - 1/2" plywood @ 13" x 4"
1 - 1/2" plywood @ 24" x 14"
1x2 boards cut to size for parquet inlay (see step 5)

Step One:

Build The Frame

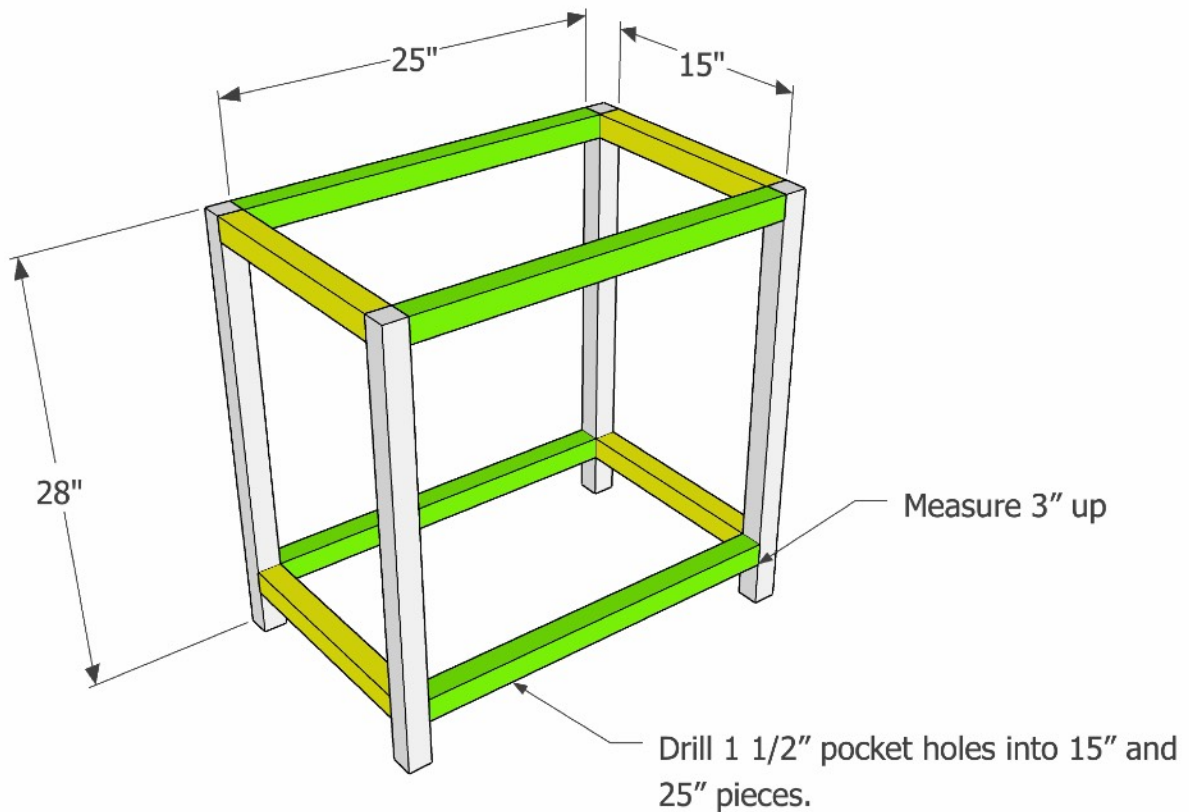

Drill 1 1/2" pocket holes into the 15" and 25" frame pieces. Attach the top frame pieces flush with the top ends of the legs using wood glue and 2 1/2" pocket screws.

Attach the bottom frame pieces 3" up from the bottom of the legs using wood glue and 2 1/2" pocket screws.

Step Two:

Attach the Side and Back Panels

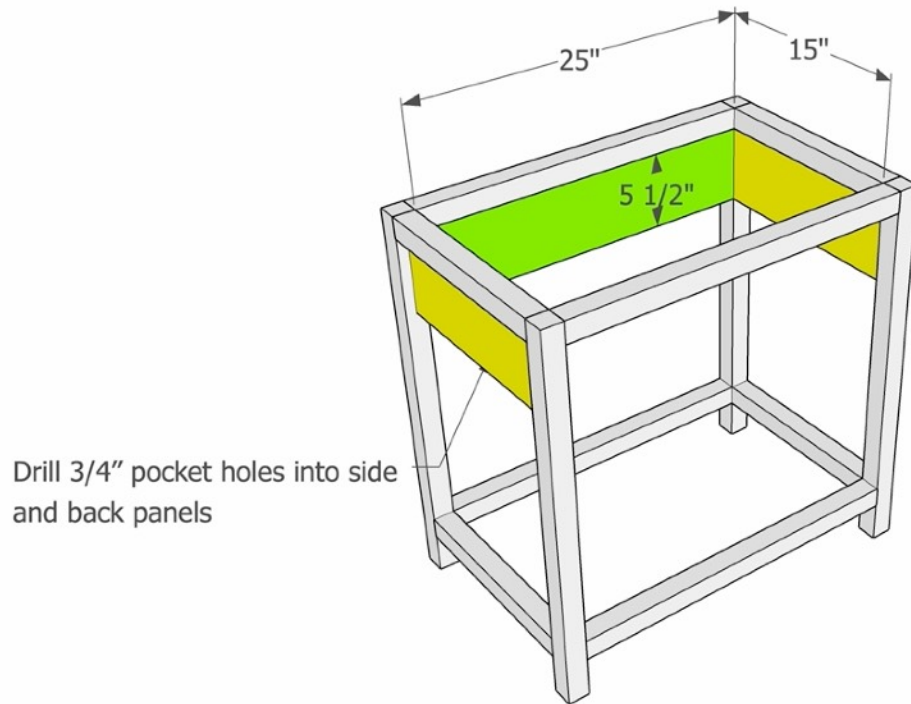

Drill 3/4" pocket holes into each end and the top edge of the 1x6 boards. Clamp and attach in place with 1 1/4" pocket screws.

Step Three:

Attach the Bottom Shelf

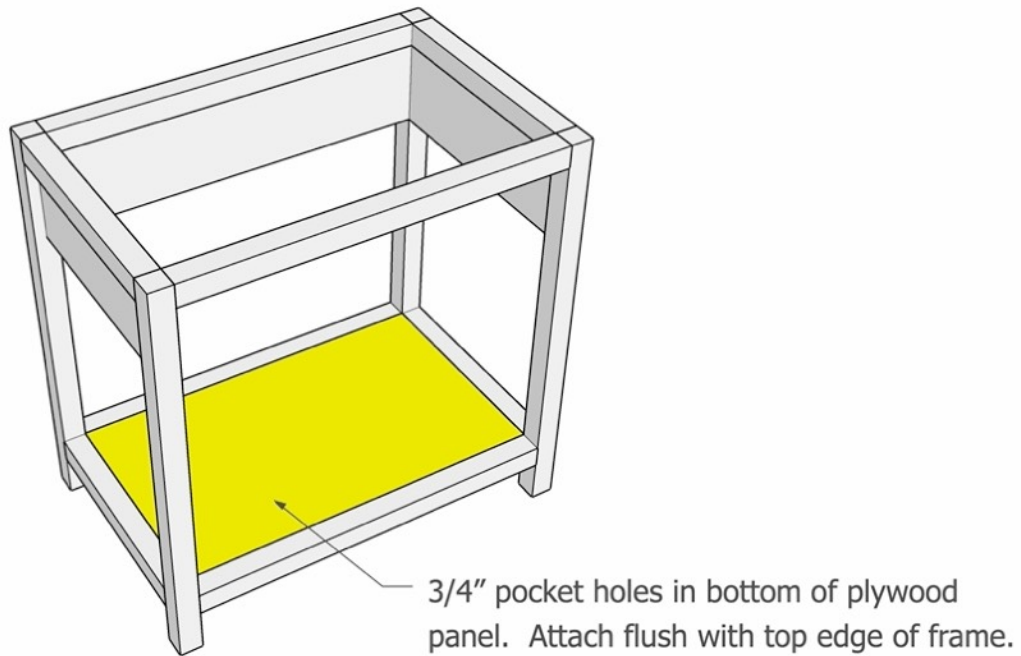

Drill 3/4" pocket holes into the bottom of the 3/4" plywood shelf. Set in place flush with the top edge of the lower portion of the frame. Clamp and attach with 1 1/4" pocket screws.

Step Four:

Add Moulding To Base of Cabinet

Attach flush with the bottom edge of the top frame.

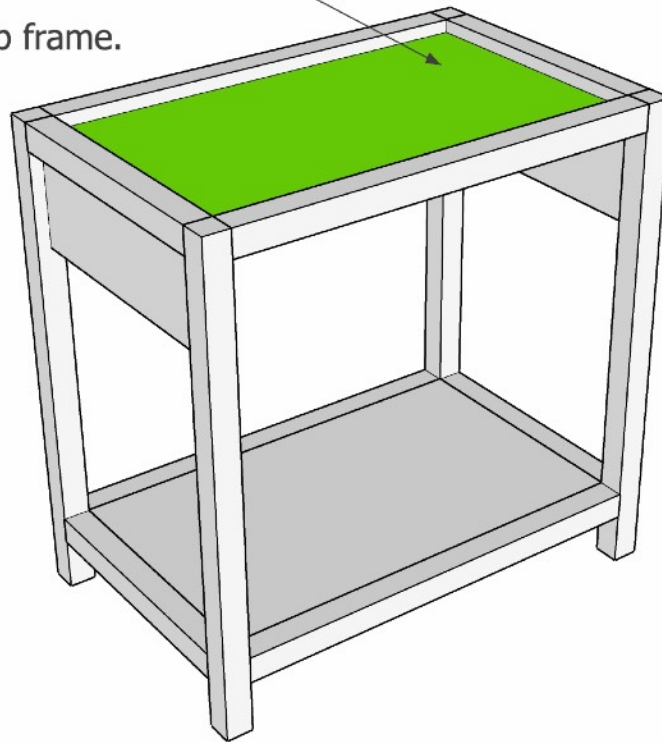

Drill 3/4" pocket holes into the underside of the upper plywood piece. Set in place so that it is flush with the bottom edge of the upper frame pieces.

Step Five:

Cut and Install The Parquet Inlay

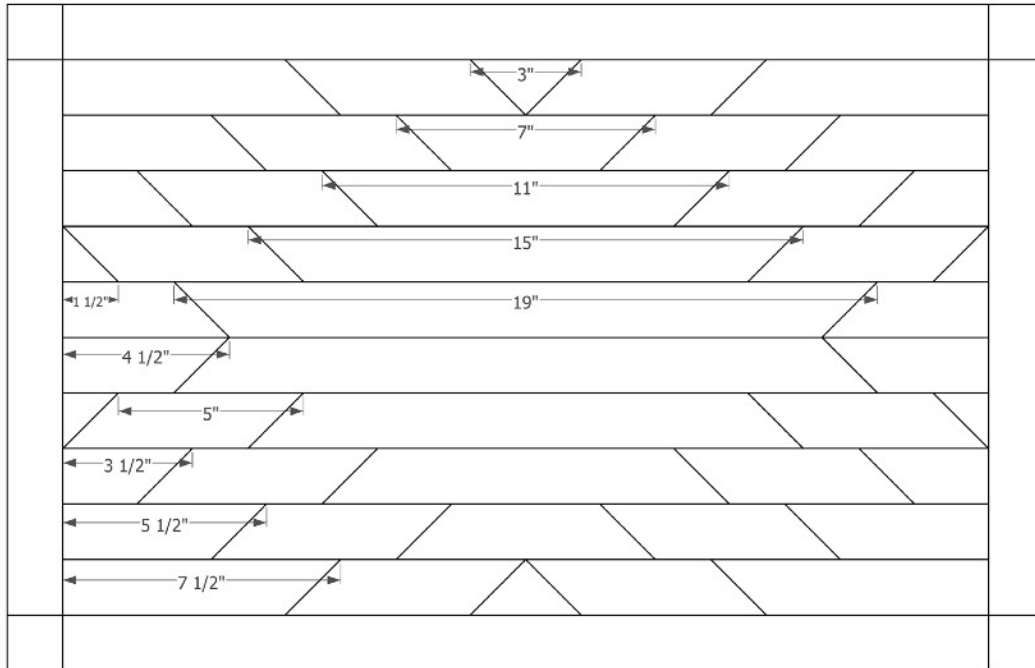

For the parquet inlay, cut 1x2 pieces based on the sizing in the diagram above. Dry fit all of the pieces in place. Once everything fits properly, glue the pieces down and (optional) nail in place with 1 1/4" pin nails.

Step Six:

Build The Drawer

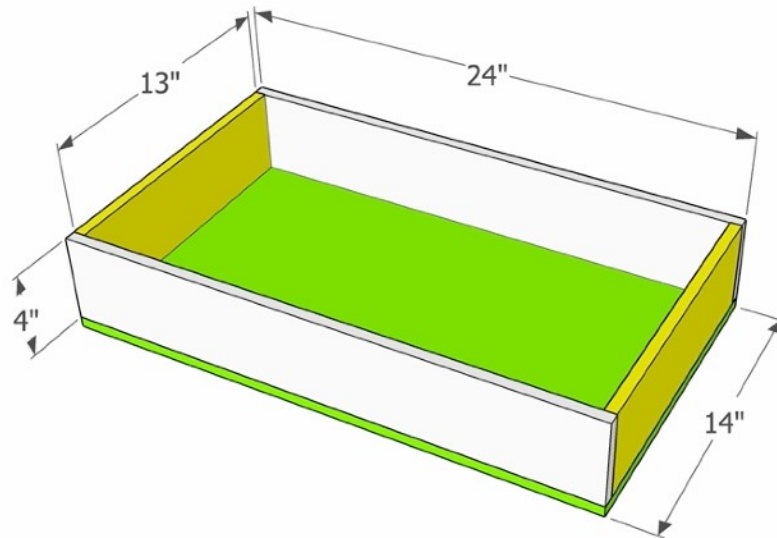

Drill 1/2" pocket holes into the side pieces of the drawer. Glue the sides to the front and back pieces and attach with 1" pocket screws. For the drawers, use 1" pocket screws that have only a round head and not a pan head, as they will allow the drawer slides to fit better.

Install the drawer using side mount or bottom mount drawer slides.

Step Seven:

Install The Drawer Front

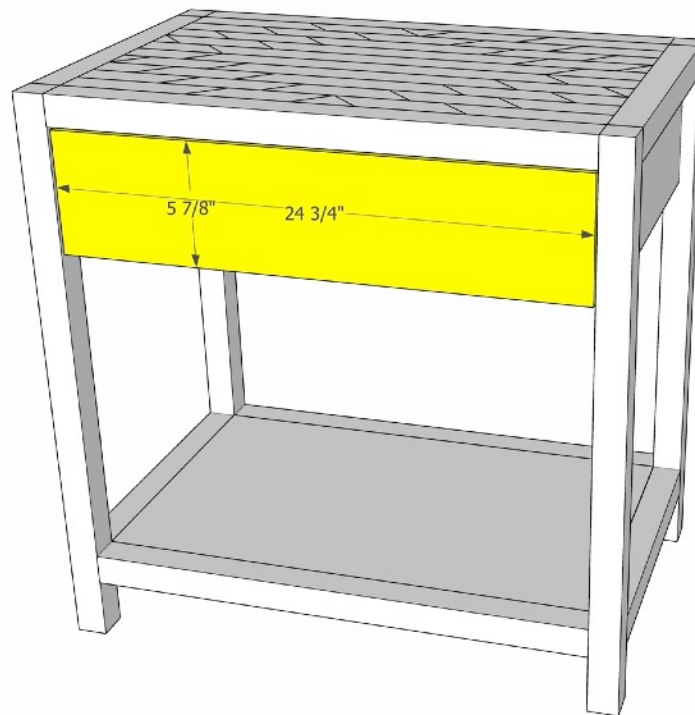

To install the drawer front, pre-drill the holes for the drawer pull hardware into the drawer front. Set the drawer front against the drawer box with an $\frac{1}{8}$ " gap around the top and sides. Stacked playing cards are a great way to set this gap.

Drill $1\frac{1}{4}$ " screws through the pre-drilled holes, into the drawer box to temporarily attach the drawer front. Pull the drawer out and attach 1" screws through the inside front of the drawer box, to fully attach the drawer front. Remove the screws in the front, finish drilling the holes for the hardware, and attach the drawer pull.