

---

# Mobile Miter Saw Bench

---

Addicted2DIY.com

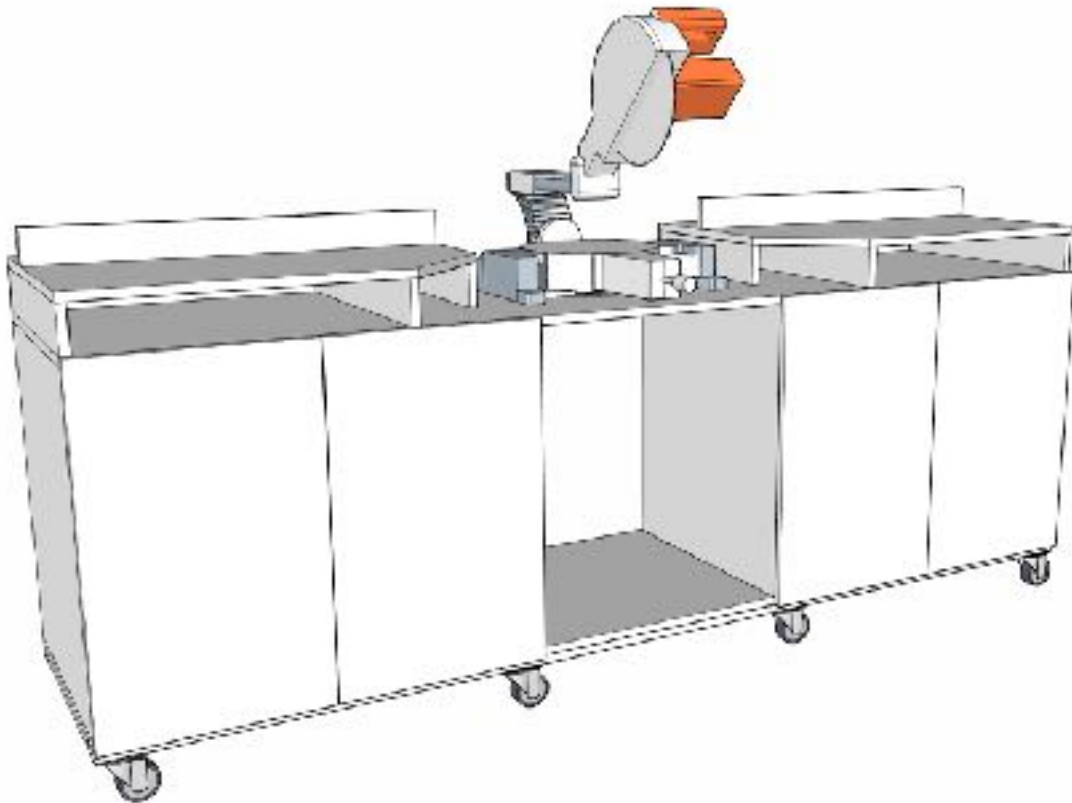

# Before beginning this project...

please read through all of the plans as well as the blog post associated with this project . Always use safety precautions whenever using power tools and follow the manufacturer's suggested guidelines. Make sure to wear proper safety protection (eye protection, hearing protection, etc.) before beginning any project. Cut all pieces per the measurements in the plans, unless noted otherwise.

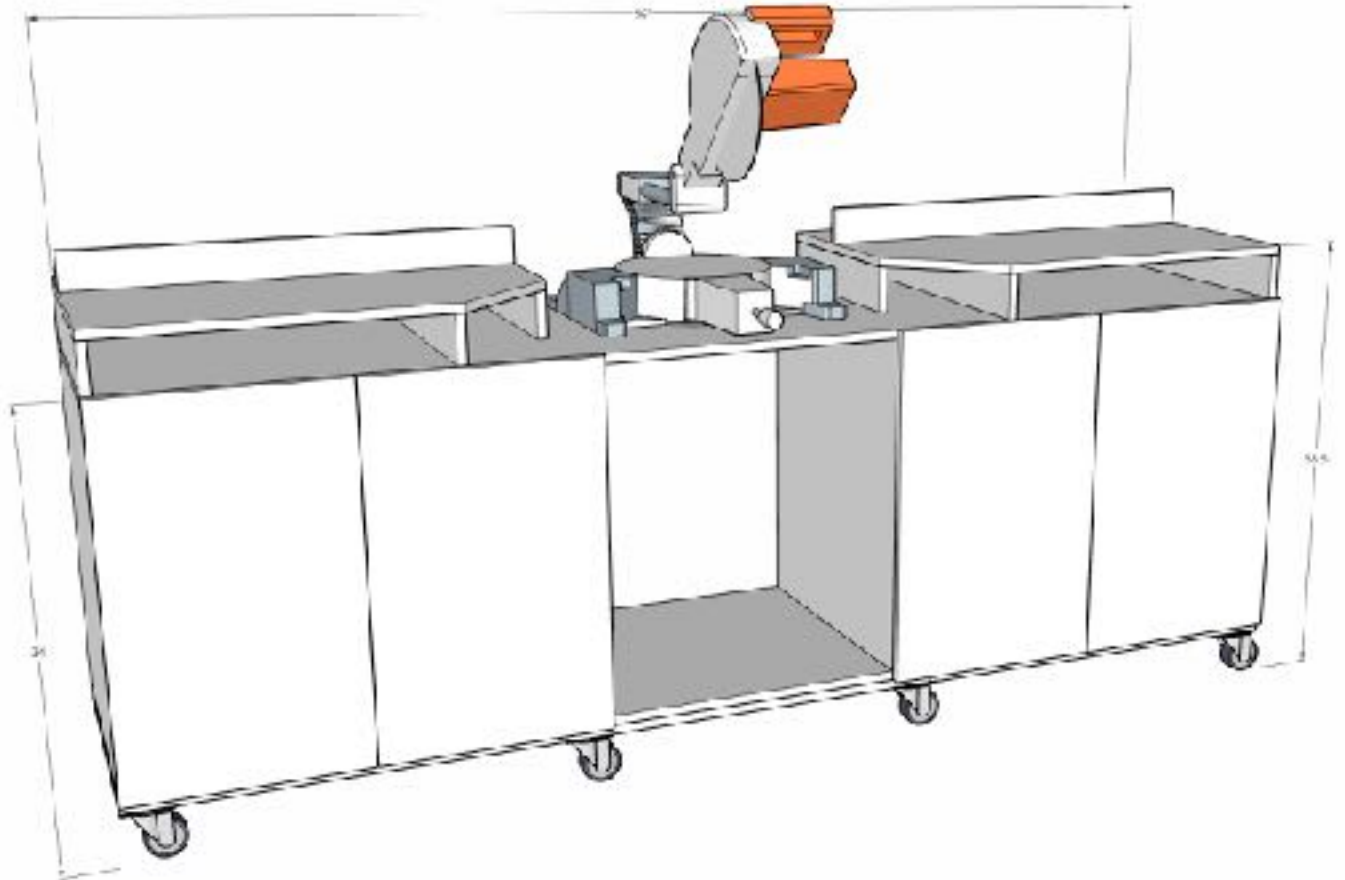

# Materials and Cut List:

## Materials Needed:

5 sheets - 3/4" plywood (I used birch veneer plywood)  
4 - 3" locking swivel casters  
4 - 3" swivel casters  
2 - 36" Rockler Double T-Track Fence Cap  
2 - Rockler 2 1/4" Fence Flip Stop  
4 sets 22" side mount drawer slides  
4 sets euro style hinges  
1 1/4" pocket screws  
1 1/4" wood screws  
1 1/4" #12 wood screws (for casters)  
1/4" finishing washers  
Wood glue  
220 grit sandpaper  
4 - threaded insert nuts  
4 - 2" bolts  
4 - washers

## Cut List: \*All pieces are 3/4" plywood

2 - 24" x 96"  
4 - 24" x 27 1/2"  
4 - 4" x 34 1/2"  
2 - 3" x 96"  
4 - 3" x 18"  
8 - 3" x 33 1/2"  
8 - 3" x 20 1/2"  
4 - 33 1/2" x 22"  
4 - 29" x 17 15/16" (doors)  
\*Cuts below based on 4 1/2" high miter saw base  
2 - 34" x 3 3/4"  
4 - 23 1/4" x 3 3/4"  
2 - 15 1/4" x 3 3/4"  
2 - 34" x 24" (table tops)  
2 - 34" x 3" (fence)

# Step One:

## *Assemble The Main Carcass*

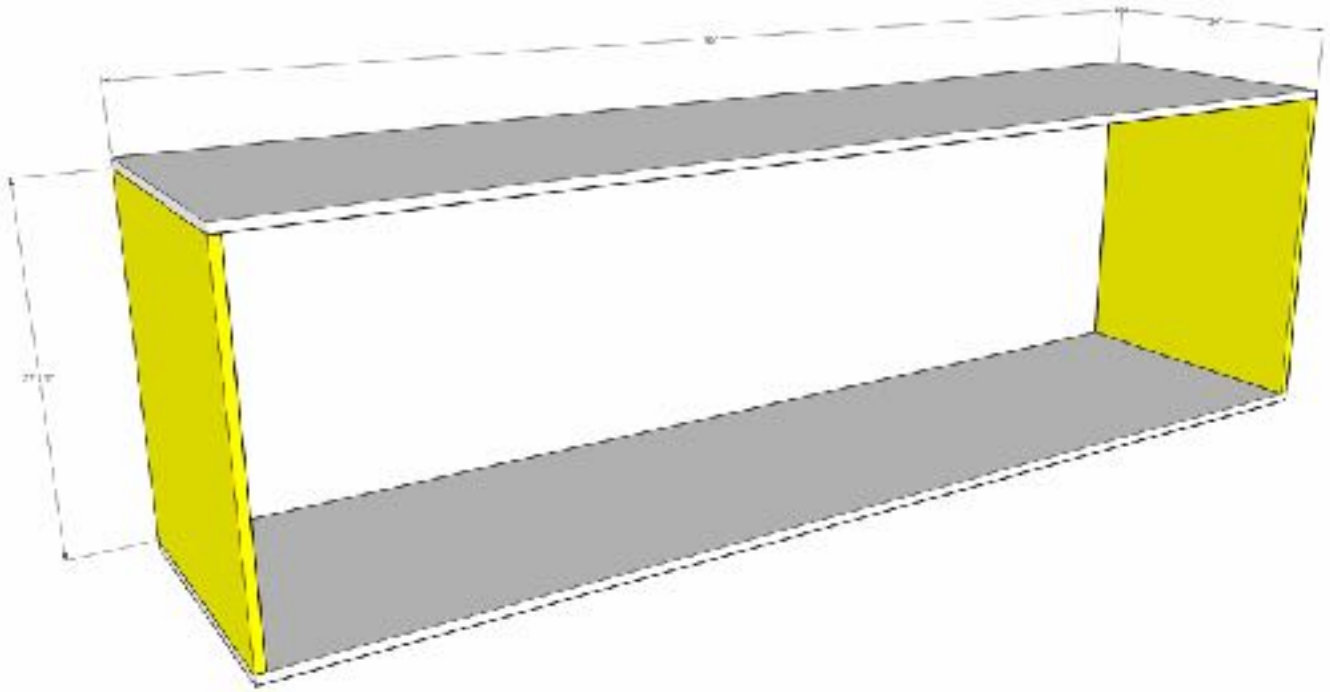

Drill 3/4" pocket holes into the upper and lower edges of the side pieces that make up the main carcass of the miter saw bench. Glue and clamp into place. Attach to the top and bottom pieces with 1 1/4" pocket screws.

# Step Two:

## *Install the Center Dividers*

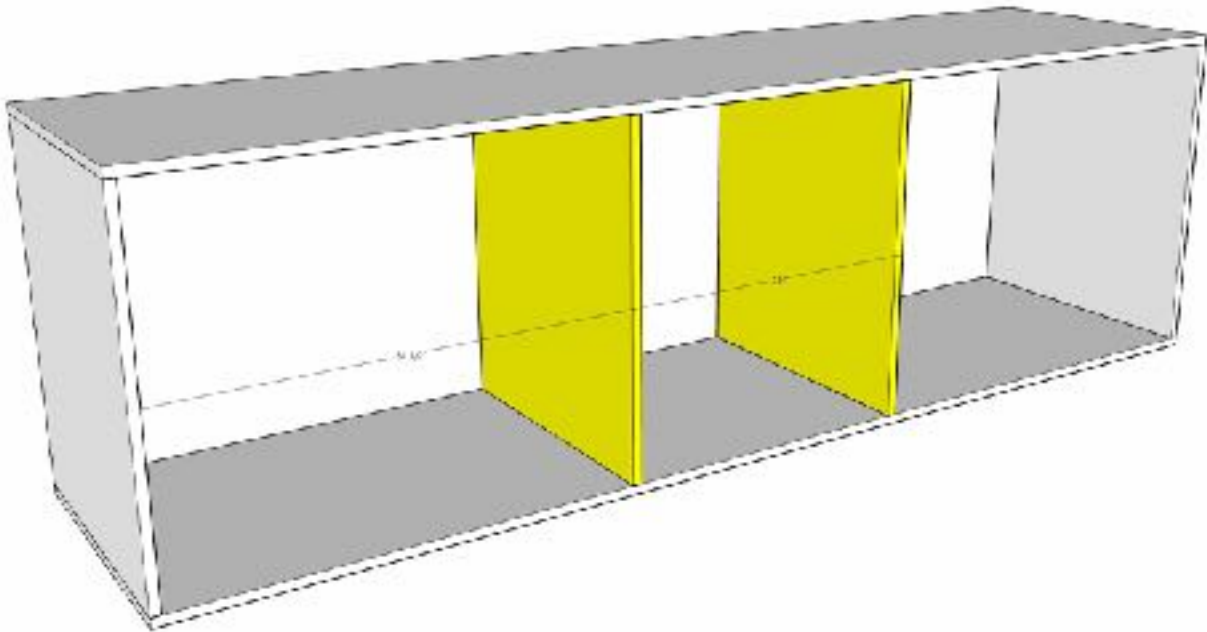

Measure and mark the locations for the center divider placement. Drill  $\frac{3}{4}$ " pocket holes into the upper and lower edges of the center dividers. Glue and clamp into place following the spacing diagram above and attach with  $1\frac{1}{4}$ " pocket screws.

# Step Three:

## *Install the Rear Stabilizing Stretchers*

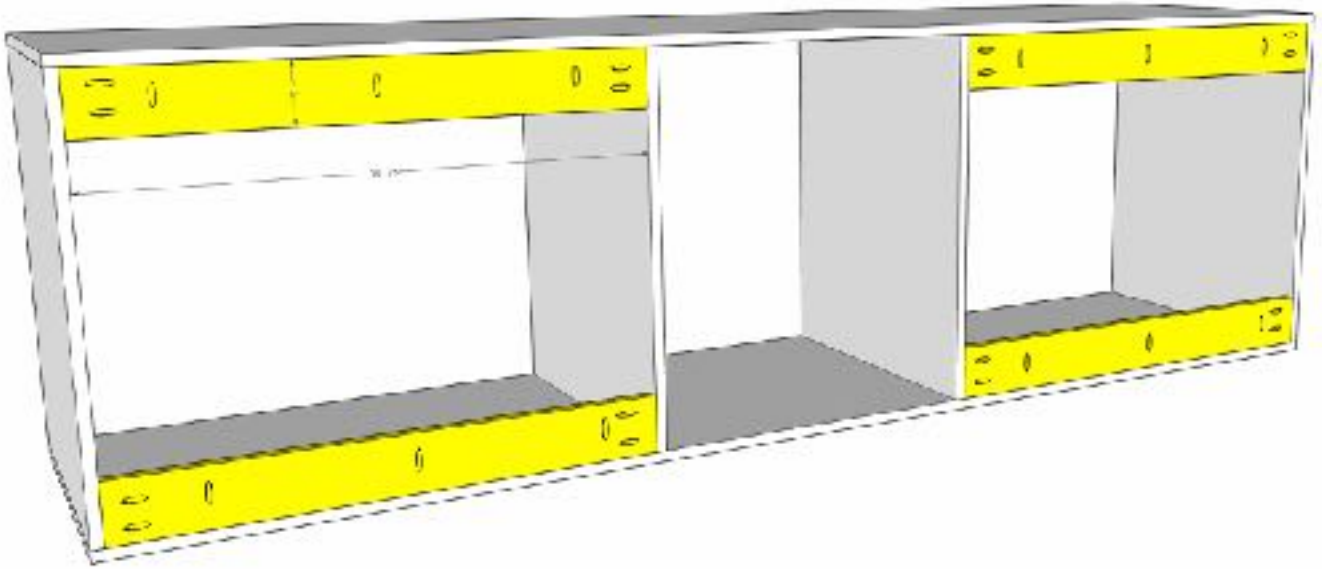

Drill 3/4" pocket holes into the ends and one edge of each of the rear stretchers. These will provide stability to the miter saw bench. Glue and clamp into place, attaching with 1 1/4" pocket screws.

# Step Four:

## *Attach the Lower Support Frame*

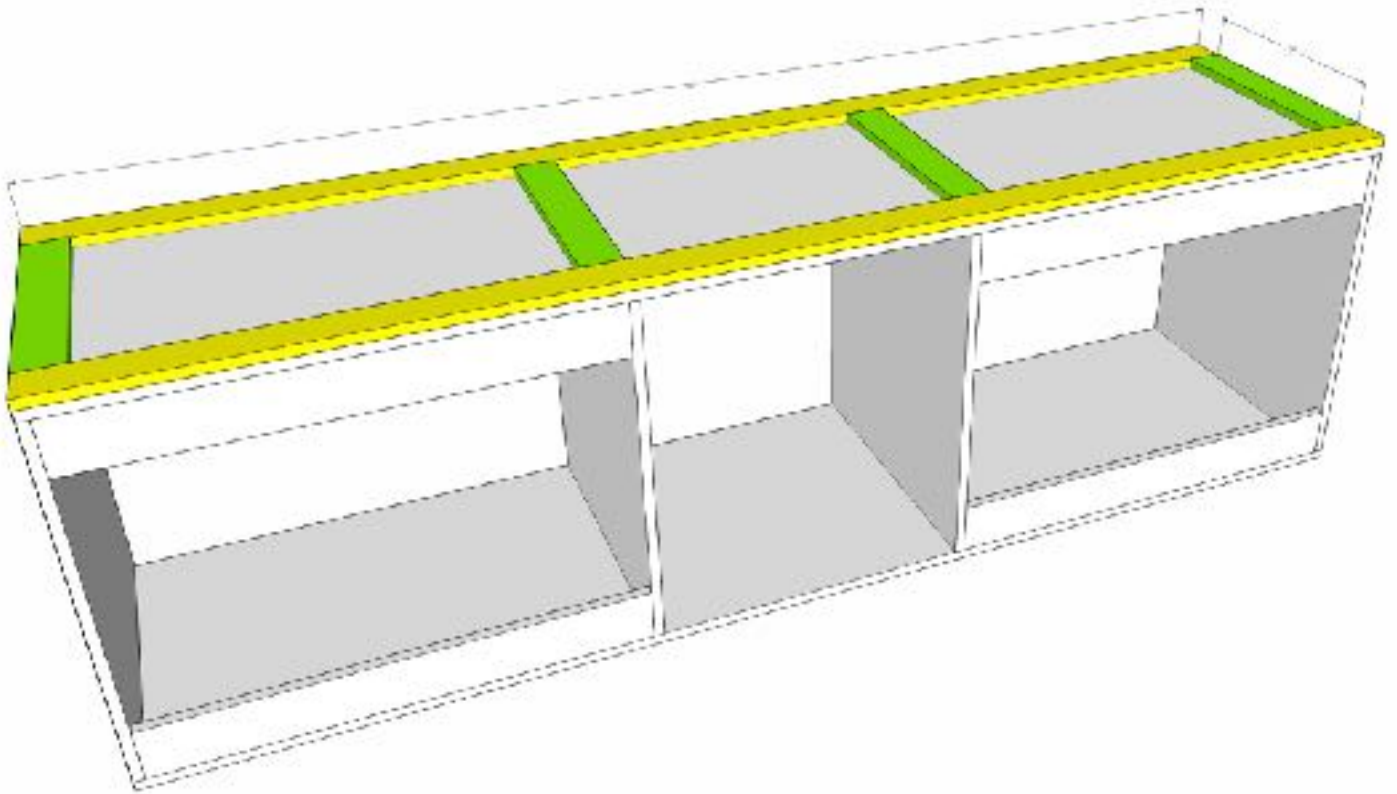

Cut the bottom support frame pieces to size. Attach the 8' pieces first, then attach the 18" pieces using wood glue and 1 1/4" wood screws.

# Step Five:

## *Attach the Casters*

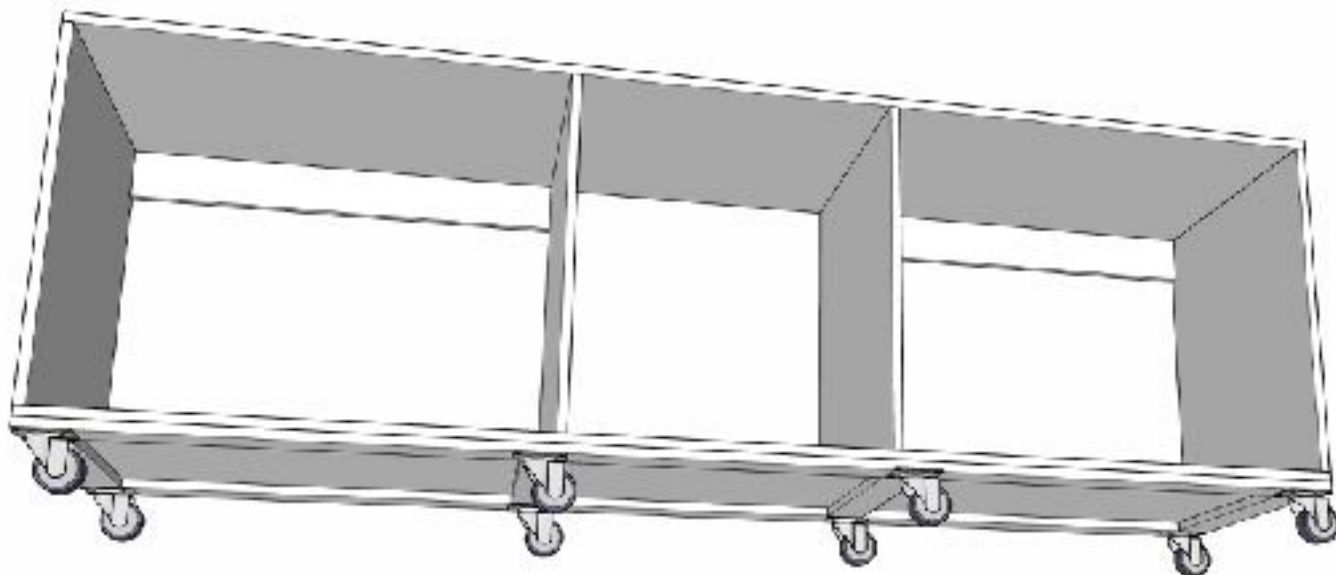

Attach the 3" swivel casters to the bottom of the miter saw bench using 1 1/4", #12 wood screws with 1/4" finish washers. Attach the locking casters to the outside corners and the standard swivel casters to the center points.



# Step Six:

## *Build the Pull Out Shelves*

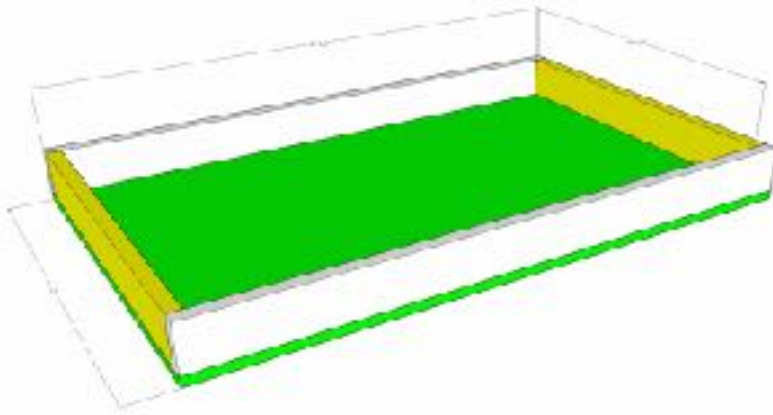

To build the pull out shelves, drill  $\frac{3}{4}$ " pocket holes into the  $20 \frac{1}{2}$ " side pieces. Glue and clamp the box together and attach the sides with  $1 \frac{1}{4}$ " pocket screws. Attach the shelf bottom with wood glue and  $1 \frac{1}{4}$ " wood screws.

Install the drawer slides to the pull out shelves and the carcass of the miter saw bench. The lower drawer slides should be installed approximately  $\frac{1}{4}$ " up from the bottom of the bench and the upper drawer slides should be installed about  $12 \frac{1}{2}$ " up from the bottom of the bench.

# Step Seven:

## *Install the Cabinet Doors*

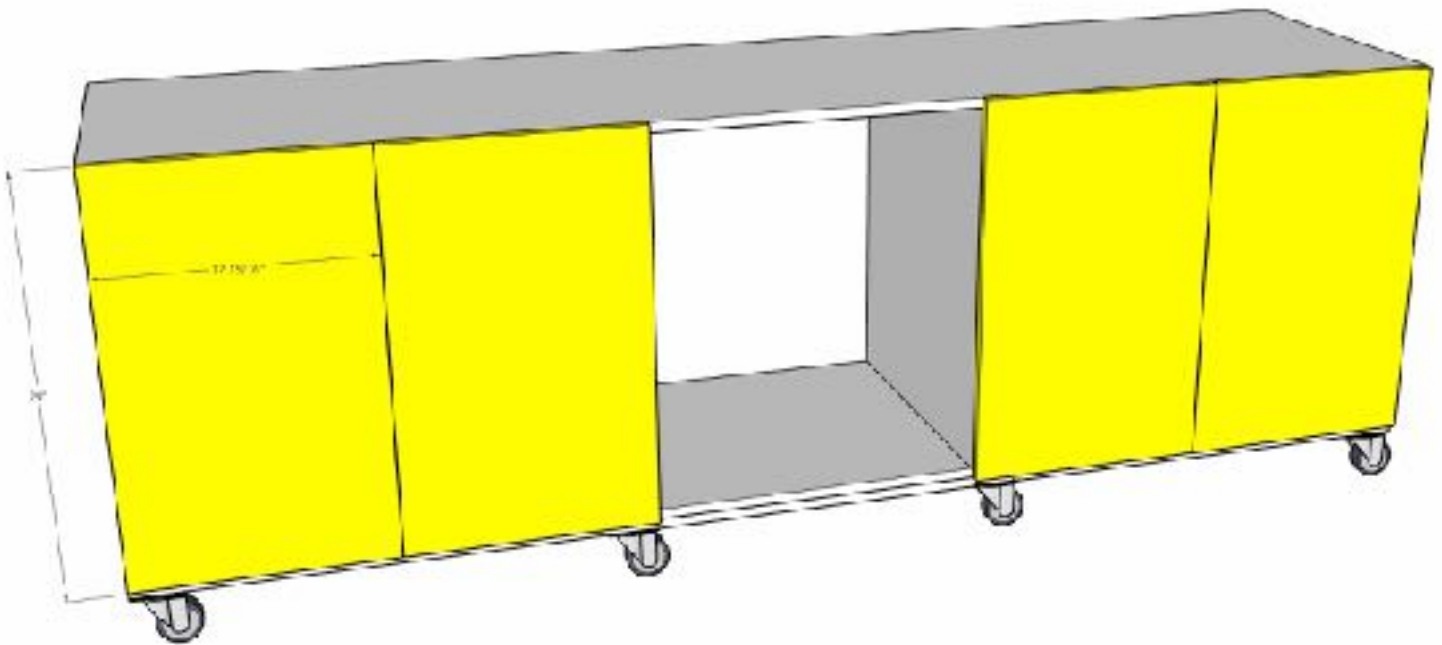

Install the cabinet doors. Measure 6" and mark from the top and bottom of the miter saw bench. Install the euro hinges at the marked locations. Attach the doors to the hinges, leaving a 1/8" gap between the doors.



# Step Nine:

## *Attach the Table Top*

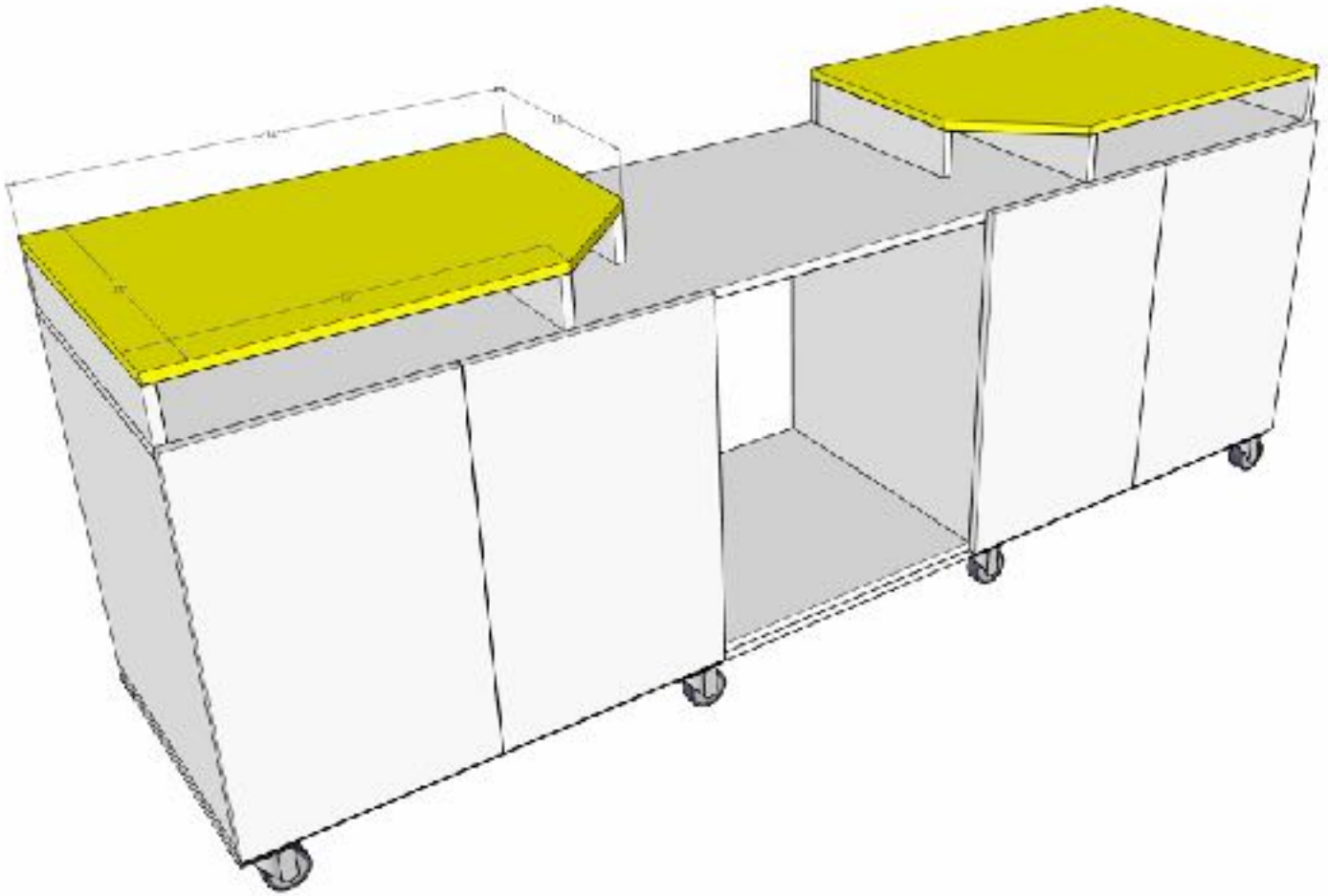

Measure and mark the table tops where the corners will be cut off to accommodate the swing of the miter saw base. Cut the corners off with a jigsaw. Attach to the table top frame using wood glue and 1 1/4" wood screws.

# Step Ten:

## *Attach the Fence*



Position your miter saw centered in between the table top risers. Make sure that the fence of the miter saw is square to the sides of the table top. Drill  $3/4$ " pocket holes into the fence pieces. Square up the plywood fence pieces to the fence on the miter saw and secure them in place with clamps and scrap wood (see accompanying video for this step). Glue and attach in place with  $1\ 1/4$ " pocket screws.

Ensure that the miter saw is still square with both fences on the table and then bolt the miter saw to the bench to secure it in place.

Cut  $1$ " off each end of the Double T-Track pieces with a grinder and file any sharp edges down. Install on top of the fence pieces with  $5/8$ " wood screws. Add the flip stops to the tracks and the tape measure inserts (if desired).